

Filling station with weighing problem

When commissioning a mixing station for liquids in a refinery, inadmissible fluctuations of the weight indicator were observed during the operation of the agitator in the mixing container. The cause was unknown.

KCE was asked to carry out a metrological investigation. In a first step, impact tests at the containers were performed with a modal hammer (batch blender and hopper). The analysis of the vibration velocities showed a natural frequency at approx. 2.4 Hz as tilting movement and another natural frequency at approx. 5.5 Hz as vertical rigid body movement of the batch blender.

Decisive for the weight signal of the installed weight cells were the vertical relative displacements at the measuring cell which are displayed in figure 2 together with the relative vibration velocity. The natural frequencies of the batch blender of approx. 2.4 Hz and 5.4 Hz with 25,000 kg filling appeared again as vibration elevation. The amplitude at 0.48 Hz was decisive for the displacement. This significant vibration was a result of the "splash behaviour" of the liquid in the container (figure 3).

The simplified calculation of this "splash behaviour" of the 1st natural frequency was carried out on the basis of the radius and the water level. A comparison of calculated and measured splash frequency at two different filling levels ($m_1 = 25,000$ kg, $m_2 = 4,390$ kg) showed a good compliance:

Mass: m_1	Mass: m_2
Filling level: 2.6 m	Filling level: 0.5 m
Calculated: 0.51 Hz	Calculated: 0.35 Hz
Measured: 0.48 Hz	Measured: 0.37 Hz

A reduction of this splash vibration could be achieved by a direct installation in the container. By adapting the electronic evaluation system the influence of the liquid splashing could be balanced (amplitude 5 μm).

MACHINE DYNAMICS

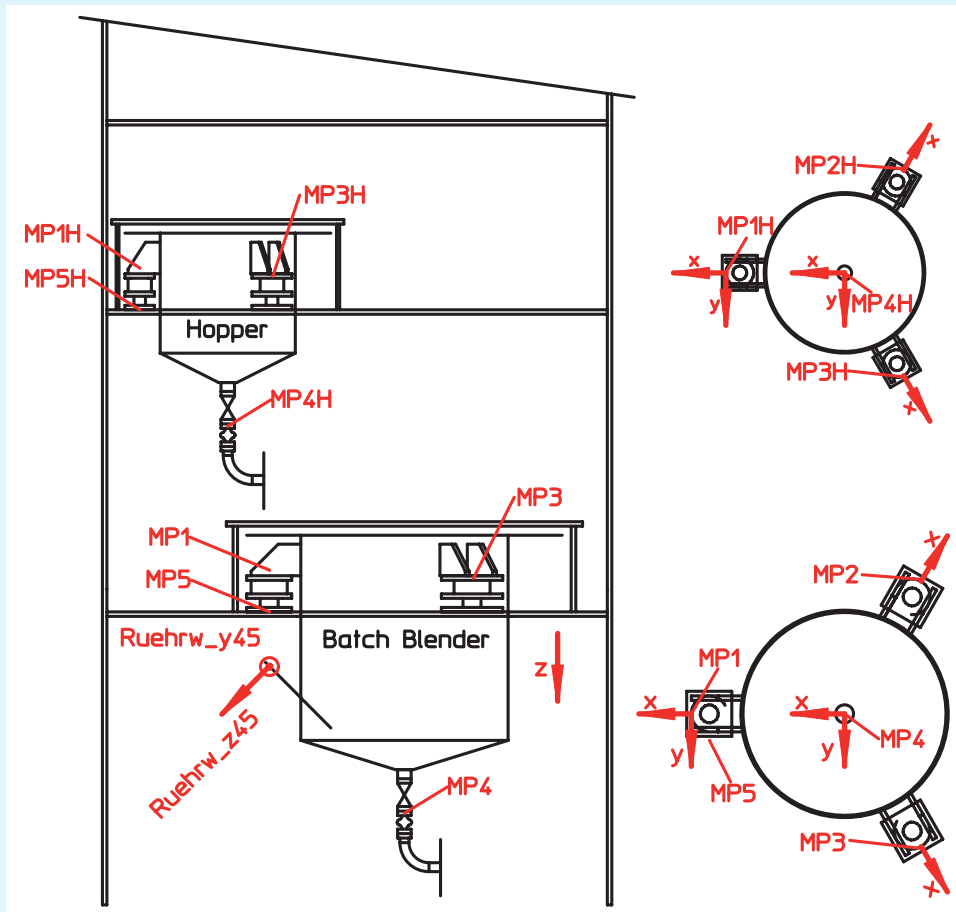

Drawing of the batch blender

MACHINE DYNAMICS

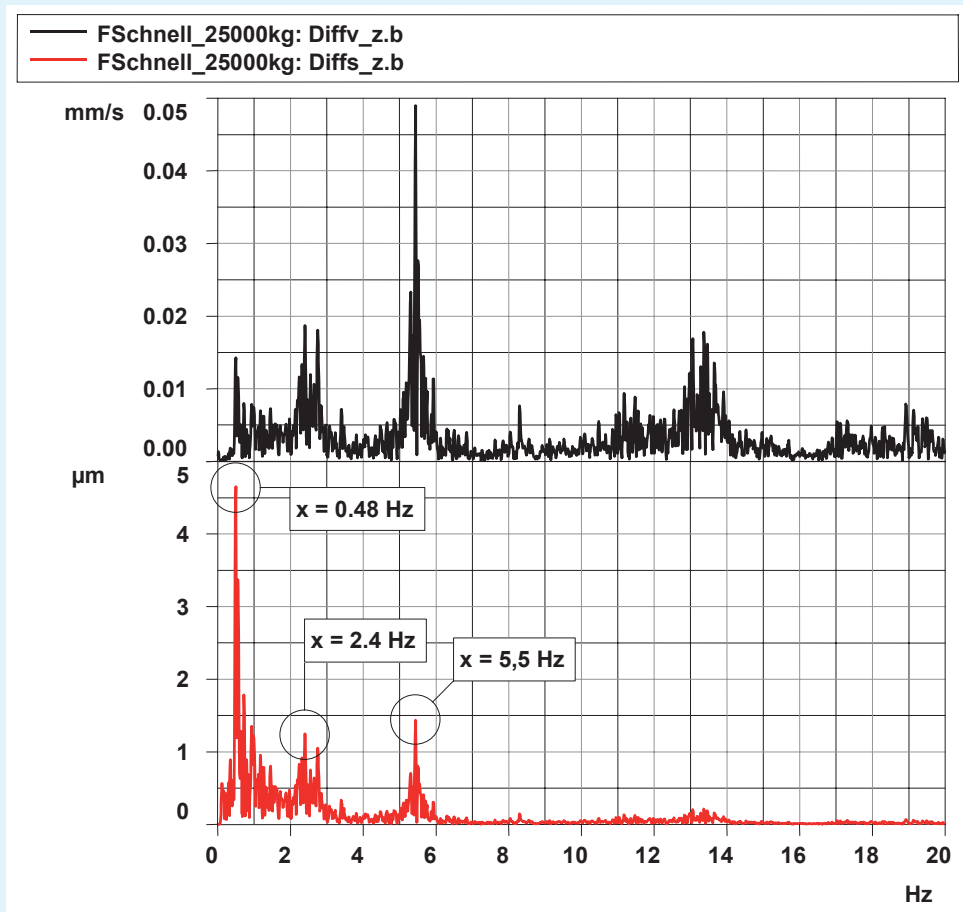

Measured vibration spectrum

MACHINE DYNAMICS

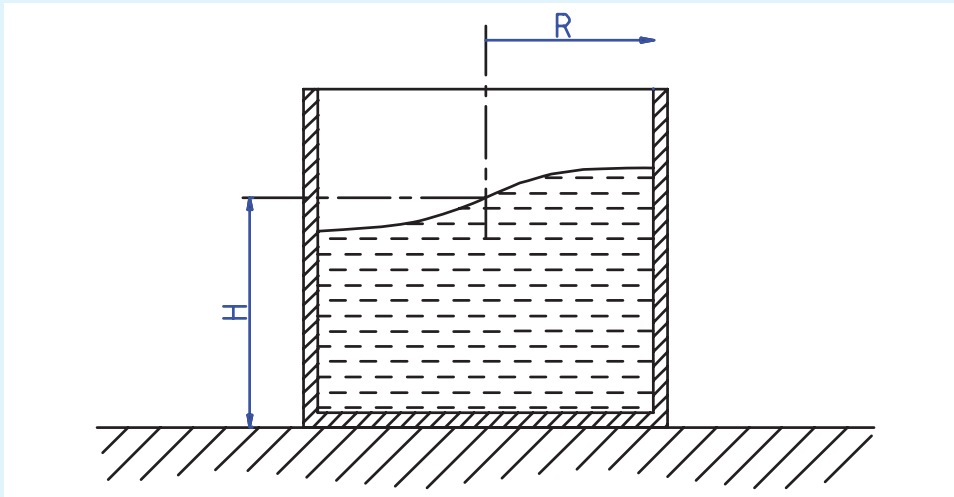

Splash behaviour of the liquid



Contact:

Dr.-Ing. Johann Lenz
Telephone: +49 5971 9710-47
j.lenz@koetter-consulting.com